

Off camera flash

Photography Lighting Techniques

Real “vintage”

My first soft box was “homemade” with satin white card, cutted off in a trapezoid shape. The edges were folded and glued on two wooden frames jointed together with clapboards. An aluminium rod, with a Nikon SB 10 flash placed in it's centre, went through the whole structure. In front of it there was a translucent plastic fastened to the frame with Velcro™ .

The good thing about my “invention” was that it looked like a parabola, which is the geometric form that allows an optimum light distribution. It's size would also broaden the lighting area of the flash, making it softer at the same time.

Then to make my own studio background, I faded a piece of blue cotton fabric with sodium hipochlorite.

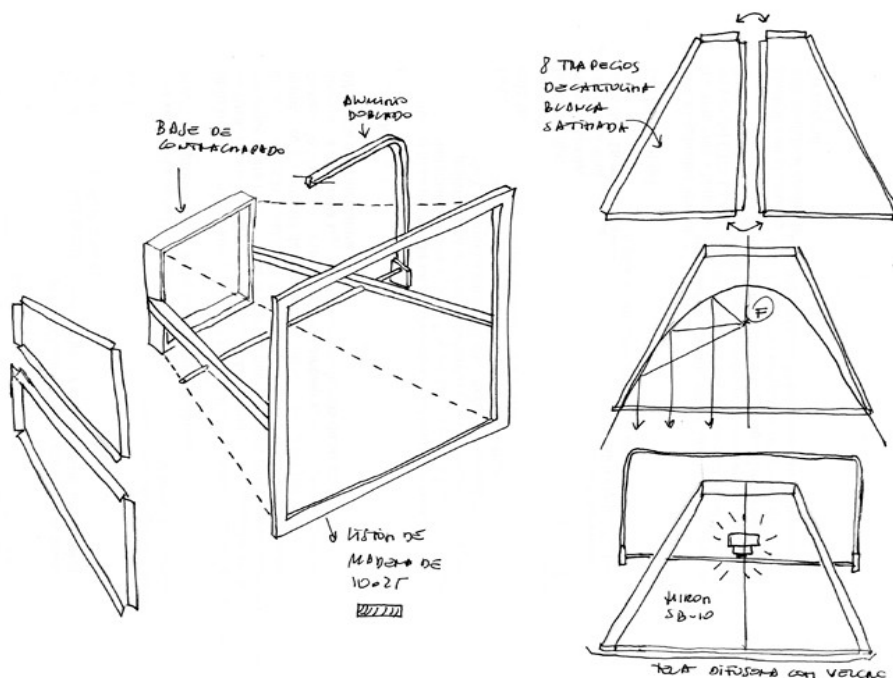

I can't recall with who I first used this “gadgets” but I do remember well spending an afternoon in my living room, doing a photo shoot with [Eduardo Galeano](#). Pure eighties style!



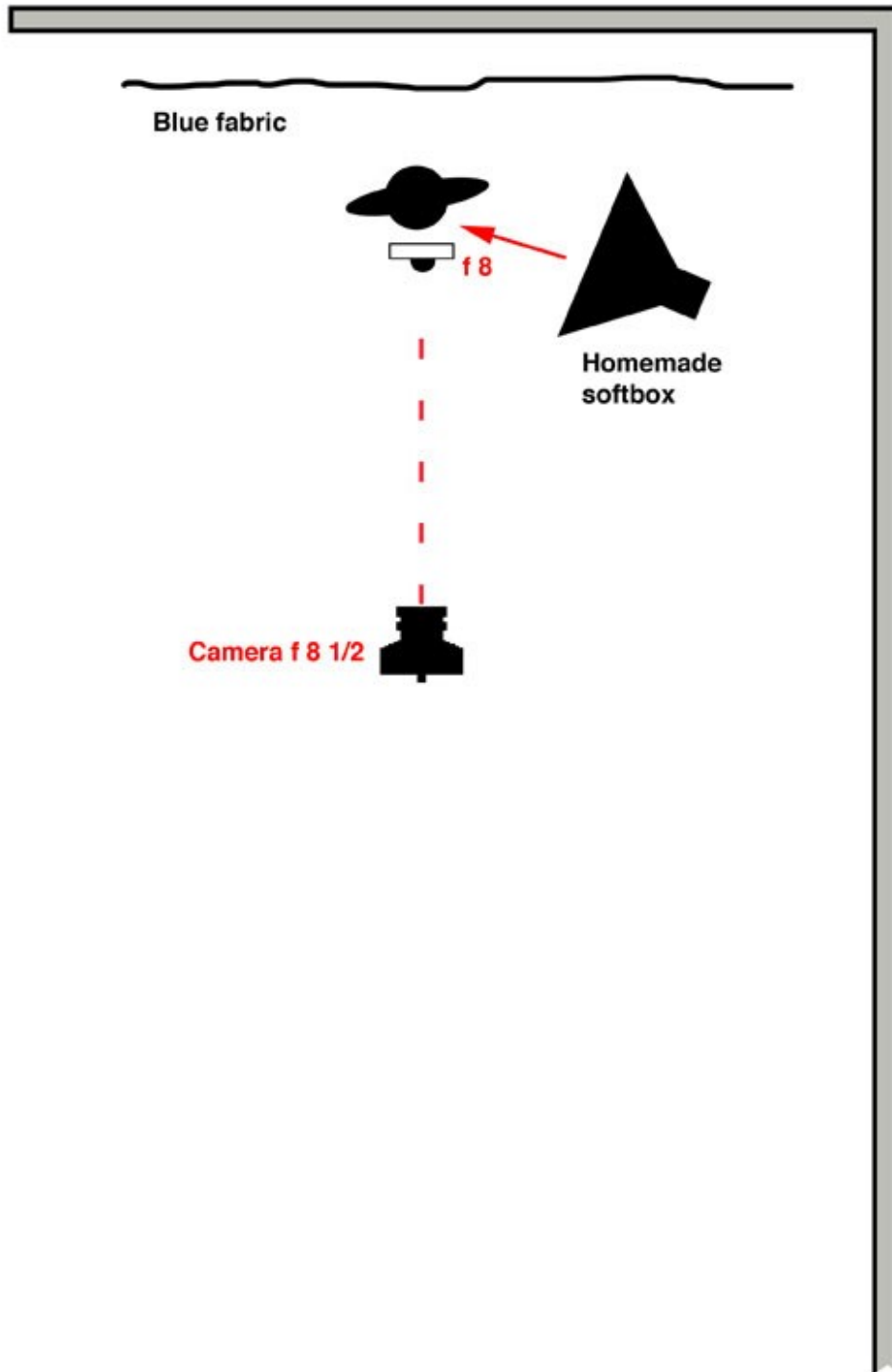

All rights reserved. © [Isarrualde Photography](#)

It is forbidden the use partial or global of this website unless authors written permission.

<http://off-camera-flash.com/english/2012/02/real-vintage>